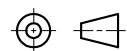

SOURCE DRAWING - FOR REFERENCE ONLY

NOTES:

- "*" INDICATES CABLE LENGTH IN METERS. CONTACT TURCK TO ORDER SPECIFIC LENGTHS.
- "/CS12852" DESIGNATES CUSTOM WIRING.

RELATED DOCUMENTS 1. 2. 3. 4.	3RD ANGLE PROJECTION 	THIS DRAWING IS CONFIDENTIAL AND THE PROPERTY OF TURCK INC. USE OF THIS DOCUMENT WITHOUT WRITTEN PERMISSION IS PROHIBITED.		TURCK INC High Technology Sensors and Automation Controls 3000 CAMPUS DRIVE MINNEAPOLIS, MN 55441 1-800-544-7769 (763) 553-7300 (763) 553-0708 fax turck.com	
		MATERIAL SEE SPECIFICATIONS	DRFT RDS APVD T.S.	DATE 08/08/12 SCALE 1=1.3	DESCRIPTION CSWM CKWM 19-19-*/CS12852
FINISH SEE SPECIFICATIONS	ALL DIMENSIONS DISPLAYED ON THIS DRAWING ARE FOR REFERENCE ONLY	UNIT OF MEASUREMENT MILLIMETER [INCH]		IDENTIFICATION NO.	REV A
A DRAWING RELEASE RDS 08/14/12	BY DATE ECO NO.	DO NOT SCALE THIS DRAWING		FILE: 777030144	SHEET 1 OF 1